

**STUDY GUIDE – CHAPTER 5**  
**ELECTRICITY AND MAGNETISM**

**1) ASSOCIATE ELEMENTARY PARTICLES WITH THEIR ELECTRICAL CHARGE**

Scientists now know that an atom is composed of even smaller particles of matter: *protons*, *neutrons* and *electrons*. The following illustration represents the distribution of these elementary particles inside the atom:

Figure 1: SUBATOMIC PARTICLES

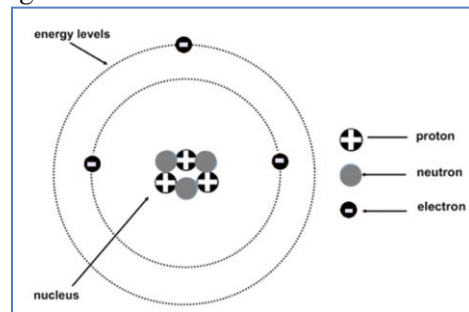

**Electrical charge** is a property of protons and electrons. It was proven that:

- **protons** are *positively* charged (+);
- **electrons** are *negatively* charged(-);
- **neutrons** have *neutral* electrical charge(*no* charge or *zero* charge);

**SAMPLE QUESTIONS:**

1) **What do protons and neutrons have in common?**

- A) They both carry an electrical charge.
- B) None of them carries an electrical charge.
- C) They are both situated outside the nucleus of an atom.
- D) They are both situated inside the nucleus of an atom.

2) **Which of the following are positively charged?**

- 1) The proton.      2) The electron.      3) The neutron.      4) The nucleus  
A) 1 and 2      B) 2 and 3      C) 3 and 4      D) 1 and 4

3) **Which one of the following sentences is true?**

- A) Positively charged objects have a deficit of protons.
- B) Positively charged objects have surplus of electrons.
- C) Negatively charged objects have a surplus of electrons.
- D) Negatively charged objects have a surplus of protons.

A) 1 and 2

B) 1 and 3

C) 2 and 4

D) 2 and 3)

2) DESCRIBE THE BEHAVIOR OF ELECTRICAL CHARGES OF OPPOSITE SIGNS OR OF THE SAME SIGN WHEN CLOSE TOGETHER

Brought close together, two electrically charged objects interact:

- when the charges are **similar**, the objects **repel** each other

<i>positive repels positive</i>	
<i>negative repels negative</i>	

- when the charges are **opposite**, the objects **attract** each other

<i>positive and negative attract</i>	
--------------------------------------	--

**SAMPLE QUESTIONS:**

- 1) The following diagram shows four different objects and their electrical charge. The positive sign (+) represents the charge of the protons and negative sign (-) represents the charge of the electrons.

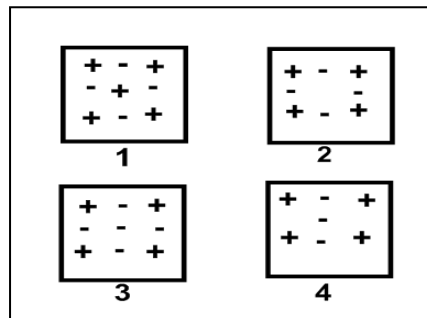



**Which of these objects are positively charged?**

- A) 1 and 2                      B) 2 and 3                      C) 3 and 4                      D) 1 and 4

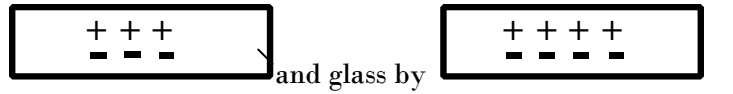
2) Silk and glass are two electrically neutral materials. Silk can be represented by

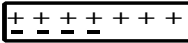

After these materials are rubbed together, silk becomes negatively charged and glass becomes positively charged. *Which of the following models may represent silk and glass after these materials have been rubbed together?*

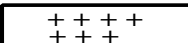
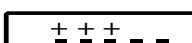
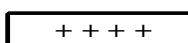
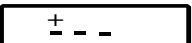
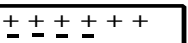
- A) silk  glass 
- B) silk  glass 
- C) silk  glass 
- D) silk  glass 

3) Five metallic spheres were electrically charged and then suspended as shown in the diagram below:

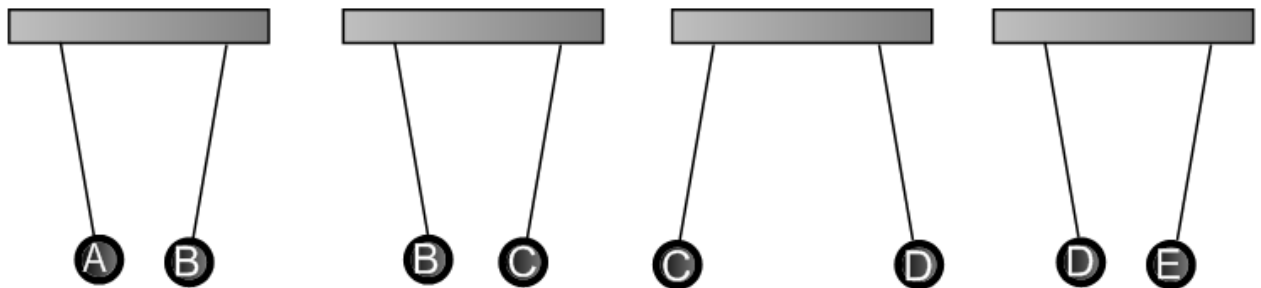

*If sphere A lost electrons, which of the spheres were negatively charged?*

- A) B and C  
 B) C and D  
 C) D and E  
 D) E and B

4. The list below arranges different substances in increasing order of their tendency to acquire electrons. When two of these substances are rubbed together, the one situated lower on the list attracts electrons from the substance above and becomes negatively charged.

**Table 1 ELECTROSTATIC SERIES CHART**

acetate	[Weak hold on electrons]
glass	
wool	
cat's fur, human hair	
calcium (Ca), magnesium (Mg), lead (Pb)	
silk	
aluminum (Al), zinc (Zn)	
cotton	
paraffin wax	
ebonite	
polyethylene (plastic)	
carbon (C), copper (Cu), nickel (Ni)	
rubber	
sulphur (S)	
platinum (Pt), gold (Au)	[Strong hold on electrons]

{www.hwdsb.on.ca/hillpark/.../Watts/.../Electrostatic\_Series\_Chart.doc}

In the laboratory, a student rubs a cotton cloth with each of the following substances: ebonite, plastic, acetate and glass. He then brings different samples together:

- 1) ebonite and plastic
- 2) plastic and acetate
- 3) acetate and glass
- 4) glass and ebonite

***In which of the situations did the objects repel each other?***

- 4) 1 and 2   B) 1 and 3   C) 2 and 4   D) 2 and 3

- 5) Tom wants to prepare a surprise party for his baby sister. Amongst other things, he wants to decorate the walls of their house with multi-coloured balloons. Once the balloons are inflated, Tom rubs them on his hair for a few seconds and then sticks them to the wall. He knows that this is possible due to friction, as the balloons become electrically charged and are attracted to the wall. ***Which of the following produced the static electricity?***

- A) The transfer of protons between the hair and the balloons.
- B) The transfer of electrons between the hair and the balloons.
- C) The transfer of electrons between the balloons and the wall.
- D) The transfer of protons between the balloons and the wall.

### 3) DESCRIBE STATIC ELECTRICITY AS THE TRANSFER OF ELECTRONS FROM ONE BODY TO ANOTHER

An electrically neutral body contains the same amount of protons (*positive charges*) and electrons (*negative charges*). Protons are very tightly bound to the nucleus and cannot be easily removed. Some electrons however, are not so tightly bound and can be transferred from one body to another. These transfers usually occur when two bodies are rubbed against each other.

- The atom that loses electrons becomes **positively charged**.
- The atom that gains electrons becomes **negatively charged**.

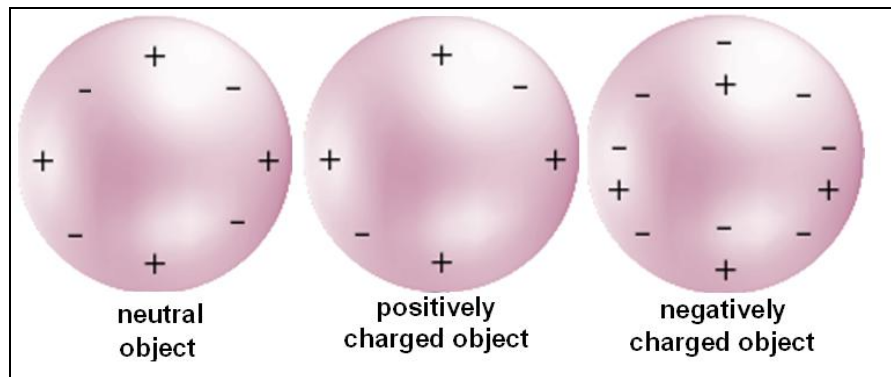

Figure 1: ELECTRICALLY CHARGED OBJECTS

Electrical charges can also be transferred from one body to another by direct contact.

#### ***SAMPLE QUESTIONS:***

- 1) ***Which one of the following sentences is true?***
  - A) The positive charge of an object comes from the transfer of protons.
  - B) The human body conducts electricity.
  - C) The lightning energy comes from the positive charges of protons.
  - D) The unit of measurement for electrical energy is the watt.

- 2) Demonstrations using ebonite rods and wool cloth are very common in static electricity. After being rubbed with wool, an ebonite rod attracts small objects. Ebonite is known to hold its electrons very tightly when rubbed against other substances. Wool on the other hand, exerts very weak attraction on its electrons.

The diagram below shows the distribution of electrical charges before the two objects (ebonite rod and wool) are rubbed together:

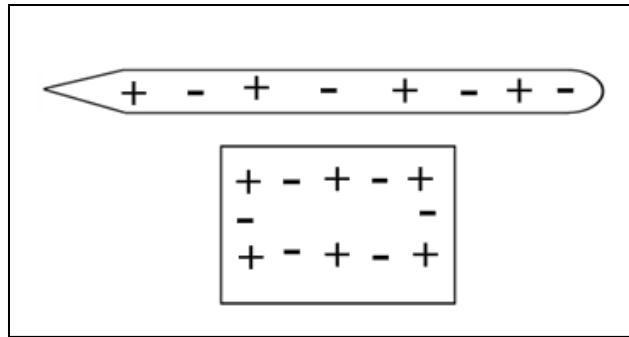

- A) Show the distribution of electrical charges in the two substances after the two objects are rubbed together (use + and -). Explain your diagram.**

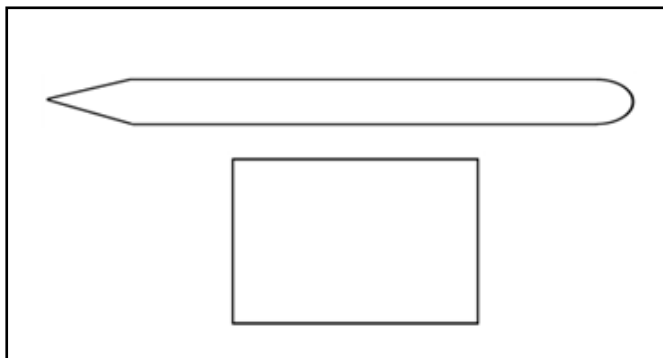

---

---

---

---

---

---

---

---

---

---

- B) Explain why the ebonite rod attracts small objects after being rubbed with the wool cloth.**

---

---

---

---

---

---

---

---

---

---

- 3) A student rubbed two identical inflated balloons on a piece of fur and suspended them from a high stand. He then rubbed a plastic ruler with a piece of wool and placed it between the two suspended balloons. The balloons quickly went high in the air as shown in the figure below.

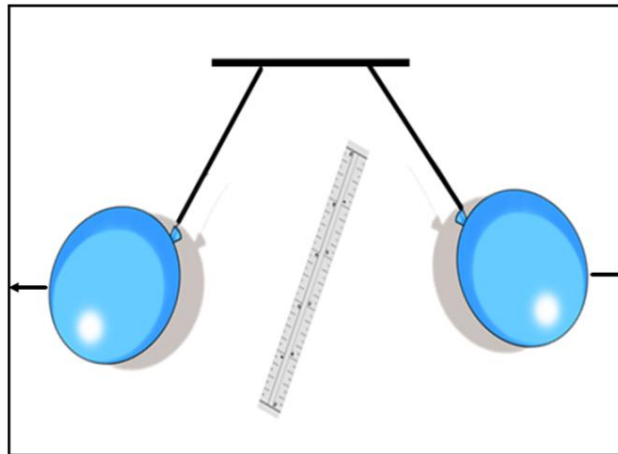

Knowing that the wool cloth transferred electrical charges to the ruler, **determine the overall charge of the wool cloth, balloons, fur and ruler, when the balloons are in the air. Explain your answer.**

	Electrical Charge (positive/negative)	Explanation
ruler		
wool cloth		
balloons		
fur		

4) **DESCRIBE THE FUNCTION OF DIFFERENT ELEMENTS OF AN ELECTRICAL CIRCUIT**

Electrical circuits transform electrical energy into other forms of usable energy (light, heat, sound, mechanical energy etc). The table below presents some components of electrical circuits and their specific role.

**Table 2 BASIC ELECTRICAL CIRCUIT COMPONENTS AND THEIR FUNCTIONS**

COMPONENT	ELECTRICAL FUNCTION	DESCRIPTION
power source, battery	power supply	creates a potential difference; transfers energy to electrons
wires	conduction	connect the elements and the power supply; carry electrons from the source to the elements and back to the source
resistors(elements)	transformation	transform electrical energy into other forms of energy (light, heat, sound etc); limit the flow of electrons
switch	control	allows the current control by connecting or breaking the circuit; (when a switch is off, the electron flow is interrupted)
ammeter		measures the current flowing through a circuit (connected in series)
voltmeter		measures the potential difference (energy) that electrons have between two points of the circuit (connected in parallel)

**SAMPLE QUESTIONS:**

1) **Which of the components depicted by the symbols below is used to STOP the electron flow in an electrical circuit?**



2) **Which of the circuit components below is designed to hinder the flow of electrons through an electrical circuit?**

- A) a copper wire      B) an alkaline battery      C) a light bulb      D) an electrical switch



3) In which of the following electrical circuits below the electron flow IS NOT possible?

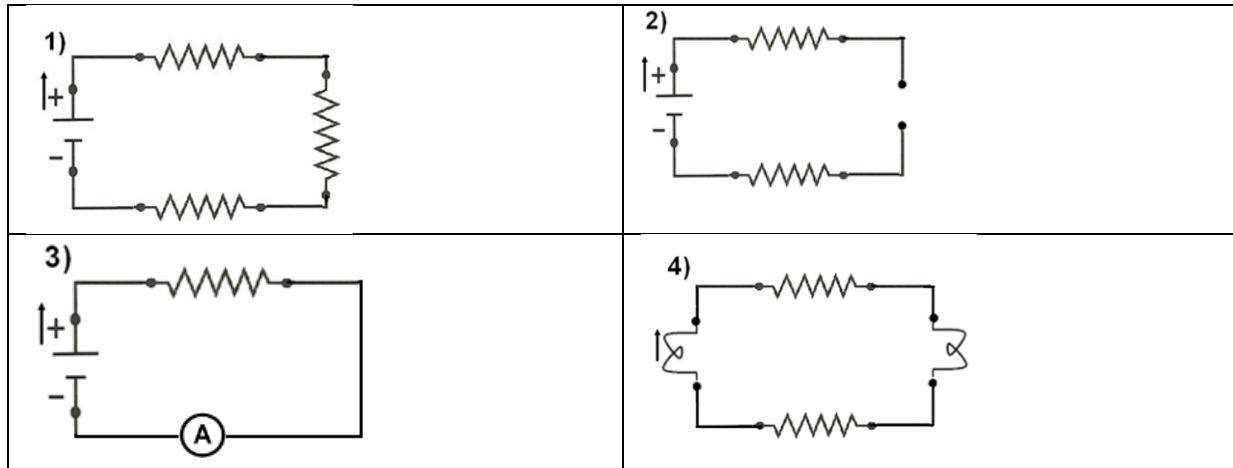

A) 1 and 2

B) 1 and 3

C) 2 and 3

D) 2 and 4

4) Draw arrows to match the components below with the right function they carry in electrical circuits:

- |  |   |
|--|---|
| <ul style="list-style-type: none"> <li>• converts electrical energy into other forms of energy</li> <li>• provides the energy to charge</li> <li>• controls the current</li> <li>• measures the current intensity</li> <li>• measures the voltage</li> <li>• carries the current</li> <li>• type of load that generates light</li> </ul> | <ul style="list-style-type: none"> <li>• ammeter</li> <li>• resistor</li> <li>• light bulb</li> <li>• voltmeter</li> <li>• power supply</li> <li>• switch</li> <li>• wires</li> </ul> |
|--|---|

5) DESCRIBE THE TWO TYPES OF CONNECTIONS IN ELECTRICAL CIRCUITS (SERIES, PARALLEL). REPRESENT A SIMPLE ELECTRICAL CIRCUIT USING A DIAGRAM

An **electrical current** is a flow of electrical charges. An **electrical circuit** is a network in which electrical charges flow continuously. In order for charges to flow, all parts of the circuit must be connected together.

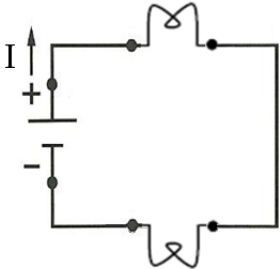
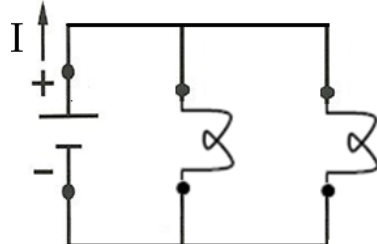
SERIES CIRCUITS	PARALLEL CIRCUITS
<p>In a series circuit, elements are linked directly together (connected end to end). All charges follow the same pathway. If a part of the circuit is open or an element is defective, the current ceases to flow through the entire circuit.</p>	<p>A parallel circuit branches out in at least one point (node). The charges follow different pathways. If a part of the circuit is open or an element is defective, the current continues to flow through the other branches.</p>
 <p>Diagram 1: SERIES CIRCUIT</p>	 <p>Diagram 2: PARALLEL CIRCUIT</p>

The **conventional current,  $I$** , represents the flow of **positive charges** (from the positive to the negative terminal).

**MEASURING INSTRUMENTS**

- Ammeters are connected **IN SERIES** (the current passes through the ammeter).
- Voltmeters are connected **IN PARALLEL** (outside the element whose voltage is measured).

Diagram 3: MEASURING INSTRUMENTS

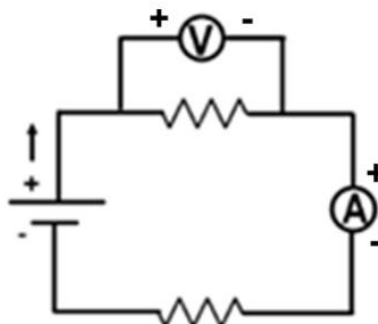

**SAMPLE QUESTIONS:**

1) Which of the circuits below are connected in parallel?

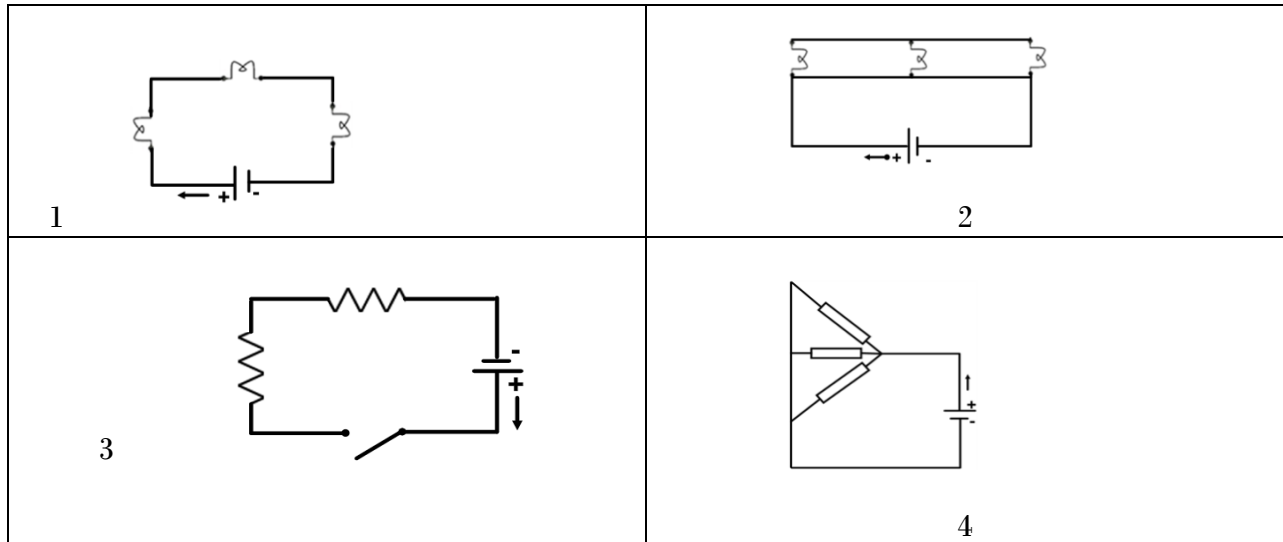

A) 1 and 4

B) 2 and 4

C) 1 and 3

D) 2 and 3

2) Four electrical circuit diagrams are given below. Which of these diagrams shows the voltmeter correctly positioned to measure the potential difference across the terminals of resistor  $R_1$ ?

A)

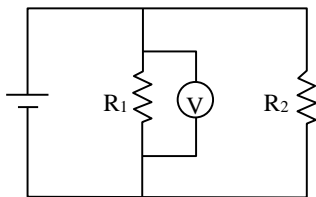

C)

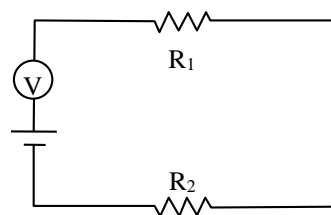

B)

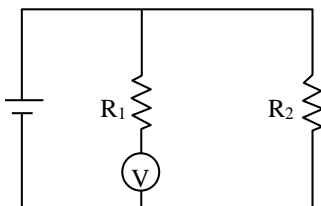

D)

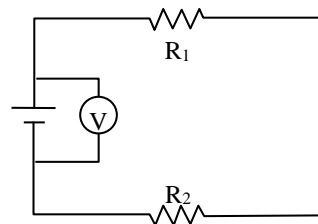

3) A circuit consists of a power supply and two light bulbs ( $L_1$  and  $L_2$ ). *Which of the following diagrams shows the correct connection for an ammeter that measures the current flowing through light bulb  $L_2$ ?*

A)

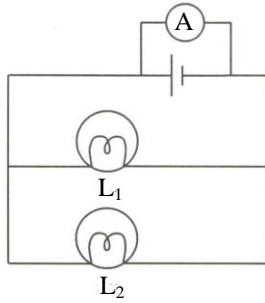

C)

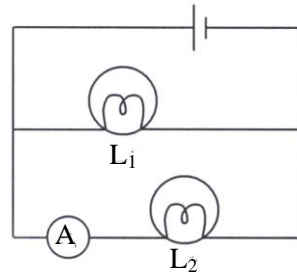

B)

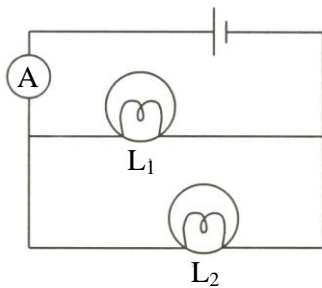

D)

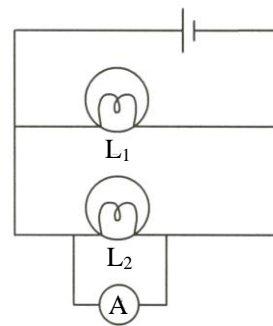

4) *In which of the circuits on the right is the voltmeter correctly connected?*

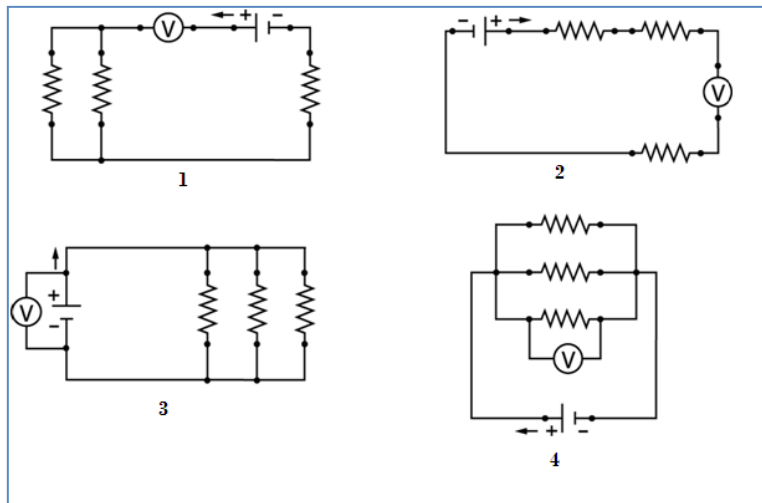

A) 1 and 2

B) 2 and 3

C) 3 and 4

D) 1 and 4

5) Which of the diagrams below represents a circuit in which the following 2 situations are possible?

- When Switch  $S_1$  is on and Switch  $S_2$  is off, only light  $L_1$  will be on.
- When Switch  $S_1$  is off and Switch  $S_2$  is on, neither light will be on

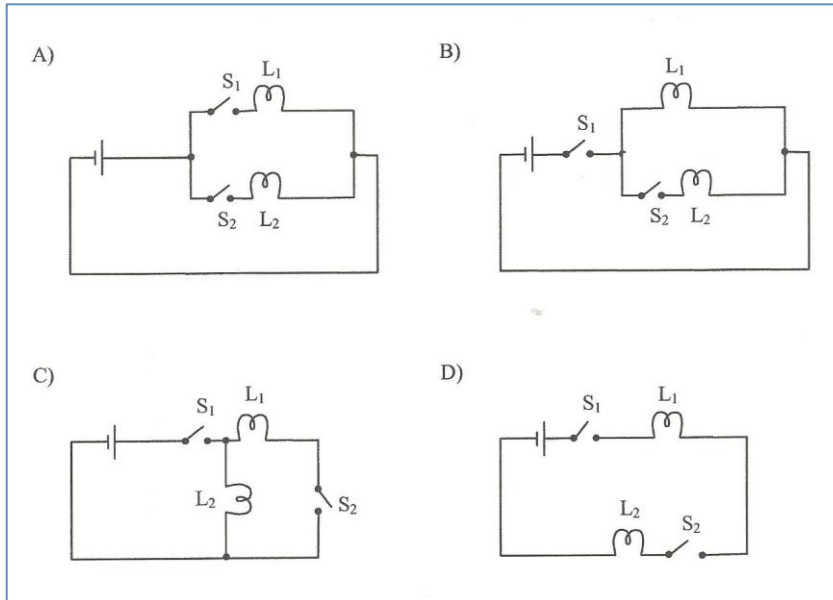

6) An electric circuit consists of a power source, two switches ( $S_1$  and  $S_2$ ) and two light bulbs ( $L_1$  and  $L_2$ ). The following table shows what happens to both light bulbs:

Switch	Switch	Light Bulb	Light Bulb
$S_1$	$S_2$	$L_1$	$L_2$
open	open	out	out
closed	open	bright	out

Which of the following circuit diagrams illustrates the results shown in the table above?

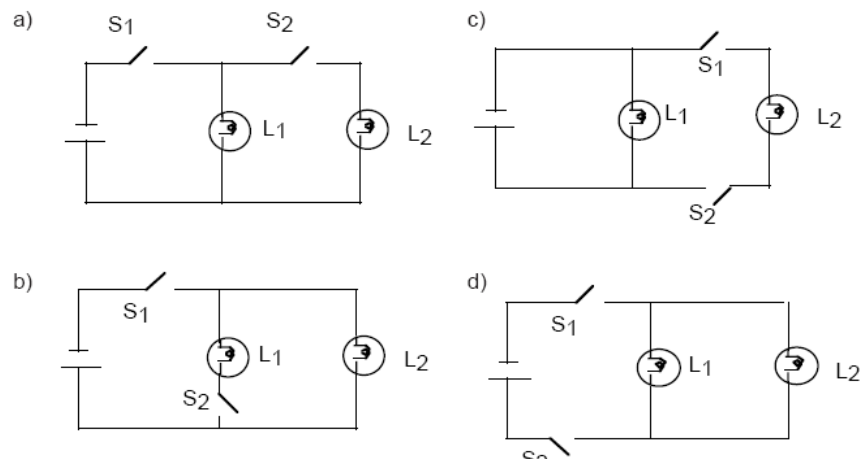

- 7) The figure below represents a simple electrical circuit containing a power source, two light bulbs and one resistor:

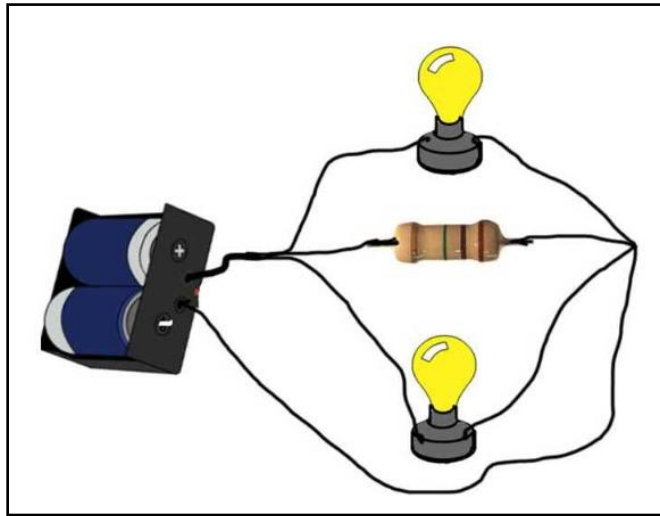

*Which of the following diagrams could represent this circuit?*

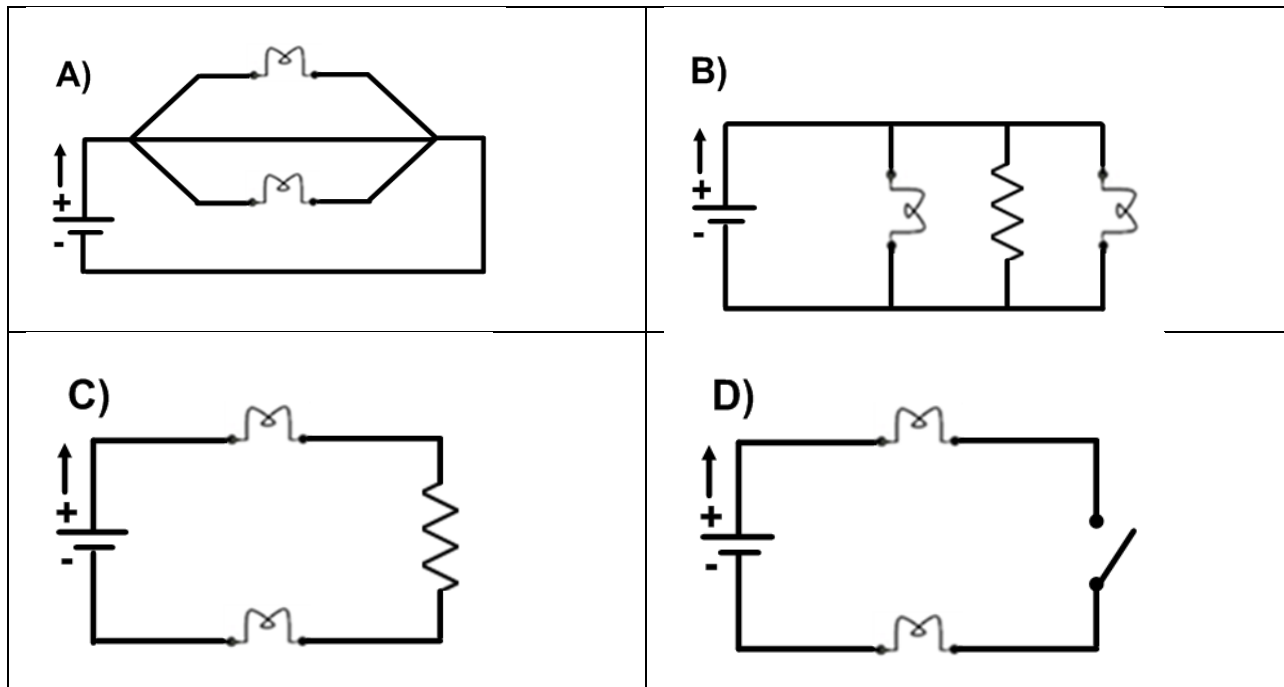

## 6) *DISTINGUISH BETWEEN ALTERNATING AND DIRECT CURRENT*

There are two types of electric current:

***DIRECT CURRENT*** (DC) - electrons continuously move in the same direction (ex. the current produced by a battery).

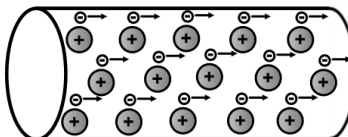

**Figure 1 MOTION OF ELECTRONS IN DIRECT CURRENT**

***ALTERNATING CURRENT*** (AC) - electrons change direction many times every second (they flow back and forth); it is produced by power plants. In North America, the current has a frequency of 60Hz which means that it changes direction 60 times every second.

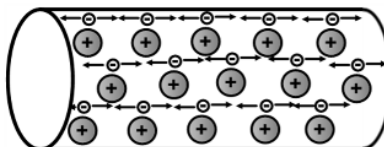

**Figure 2 MOTION OF ELECTRONS IN ALTERNATING CURRENT**

Power plants produce alternating current. This is more advantageous as during the electrical current distribution of alternating current, less energy is lost. Since most electrical appliances and electronic devices function on direct current, they usually use a regulator that transforms alternating current into direct current.

### ***SAMPLE QUESTIONS:***

**1) Which of the following statements describe an alternating current (AC)?**

- 2) It is produced by a battery
- 3) Electrons change direction continuously.
- 4) It is produced by a power plant.
- 5) Electrons move in the same direction.

A) 1 and 2

B) 2 and 3

C) 2 and 4

D) 3 and 4

**7) DESCRIBE THE RELATIONSHIP BETWEEN VOLTAGE, RESISTANCE AND CURRENT INTENSITY IN AN ELECTRICAL CIRCUIT; APPLY THE MATHEMATICAL RELATIONSHIP BETWEEN VOLTAGE, RESISTANCE AND CURRENT INTENSITY IN AN ELECTRICAL CIRCUIT**

Ohm's law describes the relationship between several important physical quantities used in electricity.

The **current intensity (I)** represents the amount of charges that flow through a point of an electrical circuit in one second.

The **potential difference (V)** is the amount of energy transferred by electrons between two points of an electrical circuit.

The **resistance (R)** of an element or a circuit is a property of materials. It represents the ability of a material to oppose (resist) the flow of electric charges.

Ohm's Law states that:

**"FOR A GIVEN RESISTANCE, THE POTENTIAL DIFFERENCE IN AN ELECTRICAL CIRCUIT IS DIRECTLY PROPORTIONAL TO THE CURRENT INTENSITY".**

The mathematical expression of Ohm's Law shows the direct proportionality between the potential difference and current intensity, for a given resistance:

$$V=R \cdot I$$

The above formula can be also written as:      -      and      -

Where:

V is the potential difference (voltage) expressed in volt (V)

I is the current intensity (current) expressed in amperes (A)

R is the resistance expressed in ohm ( $\Omega$ )

**SAMPLE QUESTIONS:**

**1) In an electrical circuit, the number of electrons crossing through the section of a wire in one second has doubled. The total resistance of the circuit stayed the same. How did potential difference change?**

- A) The potential difference halved.
- B) The potential difference doubled.
- C) The potential difference quadrupled.
- D) The potential difference stayed the same.



- 2) In the circuit diagram below the voltmeter measures 12 V and the ammeter measures 0.6 A.

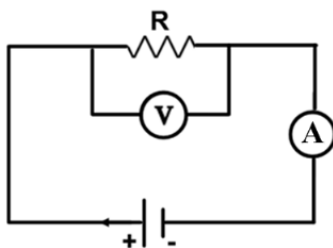

**What is the resistance of element R?**

- A) 7.2  $\Omega$                       B) 0.05  $\Omega$                       C) 20  $\Omega$                       D) 7.2 J
- 3) **What is the potential difference of a current of 10 A flowing through a resistance of 25  $\Omega$ ?**
- A) 0.4 V                      B) 250  $\Omega$                       C) 2.5 V                      D) 250 V
- 4) **You have a large flashlight that takes a 1.5 V battery. If the resistance of the light bulb is 3  $\Omega$ , what is the current in the light bulb?**
- A) 500 A                      B) 500 mA                      C) 2 A                      D) 4.5 A
- 5) **An electrical appliance has a defective resistor with a resistance of 10  $\Omega$ . You are asked to replace this resistor. The following table provides information about four resistors you have been given.**

Resistor	Potential difference (V)	Current (A)
1	2	0.4
2	6	0.5
3	15	2.5
4	20	2.0

**Which one of the above resistors could replace the defective one?**

- A) Resistor 1                      B) Resistor 2                      C) Resistor 3                      D) Resistor 4
- 6) **A circuit contains a 1.5 volt battery and a bulb with a resistance of 3 ohms. Calculate the current.**
- 7) **An alarm clock draws 0.5 A of current when connected to a 120 volt circuit. Calculate its resistance.**
- 8) **What is the voltage of a circuit with 15 amps of current and toaster with 8 ohms of resistance?**

8) **APPLY THE MATHEMATICAL RELATIONSHIP BETWEEN POWER, VOLTAGE AND CURRENT INTENSITY IN AN ELECTRICAL CIRCUIT ( $P = VI$ )**

**Electrical power** is physical quantity expressing the amount of work an electrical device can perform in one second. The electrical power of a circuit is directly proportional to both voltage and current intensity and can be expressed in a formula as:

Where:

P is the electrical power expressed in W (watt)

V is the voltage expressed in V (volt)

I is the current intensity expressed in A (amperes)

**SAMPLE QUESTIONS:**

1) A student was asked to assemble a simple electrical circuit made of a resistor and a battery and calculate its electrical power. Since he was asked to perform further calculations, he also connected also a voltmeter and an ammeter to his circuit. The diagram below represents the circuit that he assembled:

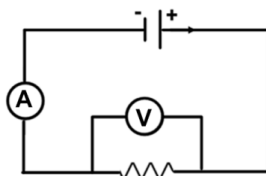

The current intensity in the circuit is 0.8 A and the voltage on the resistor is 20 V. **What is the electrical power of this circuit?**

- A) 0.04 W                      B) 16 kW                      C) 16 W                      D) 25 kW

2) **What is the current drawn when a kettle of power 1.65 kW is connected to an 110V power supply?**

- A) 0.0015 A                      B) 18.15 A                      C) 15 A                      D) 66.67 A

3) **What is the voltage required by an electric grill of power 2.2 kW and current 20 A?**

- A) 110 V                      B) 0.11 V                      C) 26.4 V                      D) 9.1 V

- 9) DESCRIBE QUALITATIVELY THE RELATIONSHIP BETWEEN THE POWER OF AN ELECTRICAL APPLIANCE, THE ELECTRICAL ENERGY IT CONSUMES AND THE AMOUNT OF TIME IT IS IN OPERATION. APPLY THE MATHEMATICAL RELATIONSHIP BETWEEN ELECTRICAL ENERGY CONSUMED, THE POWER OF AN ELECTRICAL APPLIANCE AND THE AMOUNT OF TIME IT IS IN OPERATION ( $E = P \cdot \Delta t$ )

The electrical energy of an electrical circuit can be calculated using the formula:

$$E$$

Where:

E is the electrical energy expressed in J (joule) or kWh (kilowatt hour)

P is the electrical power expressed in W (watt) or kW (kilowatt)

$\Delta t$  is the time interval expressed in seconds (s) or hours (h)

The electrical energy consumed by an electrical appliance is directly proportional to the power of the appliance and the amount of time it is in operation. In other words, the more powerful an electrical appliance is, the more energy it consumes. The longer an appliance is in operation, the more energy it consumes.

**SAMPLE QUESTIONS:**

- 1) Which of the following would reduce the cost of using an electrical appliance?

1. Increase the operation time.
2. Use an appliance with a lower power rating.
3. Use a cheap appliance.
4. Reduce the operation time.
5. Use an appliance with a higher power rating.
6. Use a new appliance.

- A) 1 and 3      B) 2 and 4      C) 3 and 5      D) 4 and 6

- 2) How much energy does an electric heater of power 200 W give off in 2 minutes?

- A) 400 J      B) 24 kJ      C) 100 J      D) 0.01 kJ

- 3) What is the energy consumed by an oven with an electrical power of 4 kW which is in use for 2.5 hours?

- A) 0.9 kWh      B) 10kJ      C) 10 kWh      D) 0.625 kJ

- 4) What is the time taken for a fire of power 2 kW to use 30 000 J of energy?

- A) 15 s      B) 15000 s      C) 60 min      D) 0.07 h

5) *What is the power of an electric bulb that gives off 3600 J of energy in 10 minutes?*

- A) 6 kW      B) 360 W      C) 2.8 kW      D) 60 W

6) This morning, Julie did the following:

- She turned on a 40-W lamp and left it for 1 hour and 18 minutes.
- For 54 minutes, she listened to a radio with a power of 5 W.
- She took a shower.
- She did her laundry in warm water.

The following table indicates the amount of electrical energy consumed during certain activities.

ENERGY CONSUMED FOR DIFFERENT ACTIVITIES

Activity	Energy consumed (W•h)
bath	3600
Shower	2400
Warm water laundry	2590
Cold water laundry	240

*Using this information, determine the total amount of electrical energy Julie used this morning. Show all your work.*

10) DESCRIBE THE FORCES OF ATTRACTION AND REPULSION BETWEEN MAGNETS AND FERROMAGNETIC SUBSTANCES

All magnets have a *magnetic field*. The **magnetic field** is the *space* around a magnet where *magnetic forces* are felt (both attraction and repulsion). The Lines of force show you the *shape, direction,* and *strength* of the magnetic field around a magnet. The shape is shown by lines of force which can be straight, curved, circular, etc. The direction is shown by arrowheads; the direction is always from **North to South**. The strength is shown by how close the lines are to each other. The closer the lines of force are, the stronger the magnetic field.

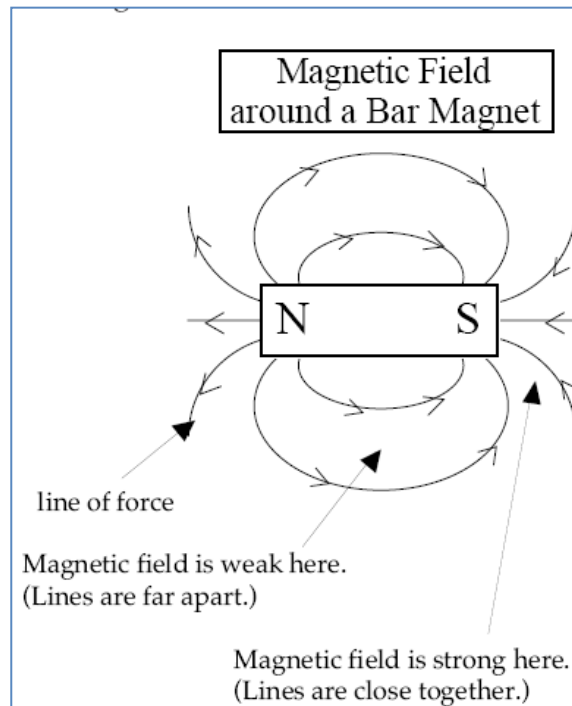

**SAMPLE QUESTIONS:**

1) Draw the *magnetic field* between the following poles:

a	b	c
<div style="display: flex; justify-content: space-around; align-items: center;"> <div style="border: 1px solid black; background-color: yellow; padding: 5px; margin: 2px;">N</div> <div style="border: 1px solid black; background-color: yellow; padding: 5px; margin: 2px;">S</div> </div>	<div style="display: flex; justify-content: space-around; align-items: center;"> <div style="border: 1px solid black; background-color: yellow; padding: 5px; margin: 2px;">S</div> <div style="border: 1px solid black; background-color: yellow; padding: 5px; margin: 2px;">N</div> </div>	<div style="display: flex; justify-content: space-around; align-items: center;"> <div style="border: 1px solid black; background-color: yellow; padding: 5px; margin: 2px;">S</div> <div style="border: 1px solid black; background-color: yellow; padding: 5px; margin: 2px;">S</div> </div>

2) Determine whether there is an *attractive* or *repulsive* force between the following pairs of magnets.

a	b	c	d
<div style="display: flex; justify-content: space-around; align-items: center;"> <div style="border: 1px solid black; background-color: gray; padding: 5px; margin: 2px;">N</div> <div style="border: 1px solid black; background-color: gray; padding: 5px; margin: 2px;">S</div> </div>	<div style="display: flex; justify-content: space-around; align-items: center;"> <div style="border: 1px solid black; background-color: gray; padding: 5px; margin: 2px;">N</div> <div style="border: 1px solid black; background-color: gray; padding: 5px; margin: 2px;">N</div> </div>	<div style="display: flex; justify-content: space-around; align-items: center;"> <div style="border: 1px solid black; background-color: gray; padding: 5px; margin: 2px;">S</div> <div style="border: 1px solid black; background-color: gray; padding: 5px; margin: 2px;">S</div> </div>	<div style="display: flex; justify-content: space-around; align-items: center;"> <div style="border: 1px solid black; background-color: gray; padding: 5px; margin: 2px;">S</div> <div style="border: 1px solid black; background-color: gray; padding: 5px; margin: 2px;">N</div> </div>

\_\_\_\_\_

3) Indicate the polarity (N or S) in the space indicated for the following pairs of magnets:

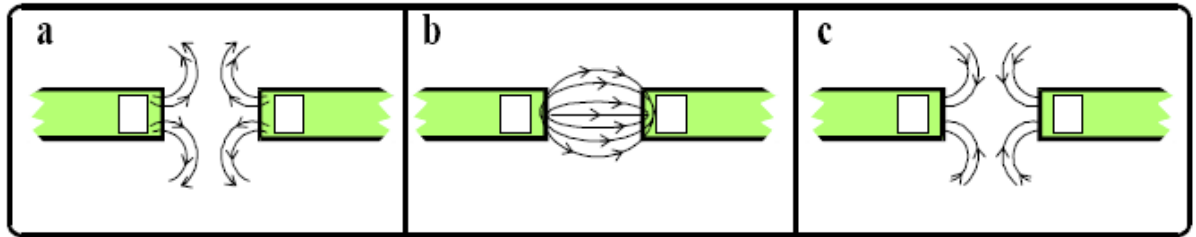

4) Draw the magnetic field around the following bar magnet:

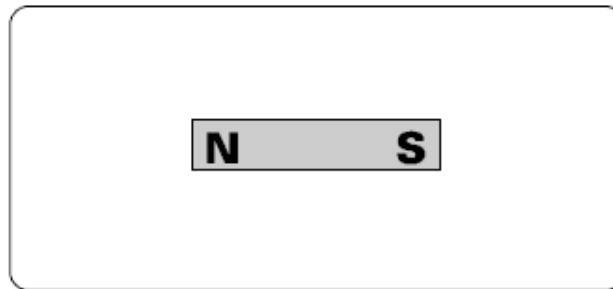

5) Two magnets are placed end to end. Which diagram correctly illustrates the magnetic fields around these magnets?

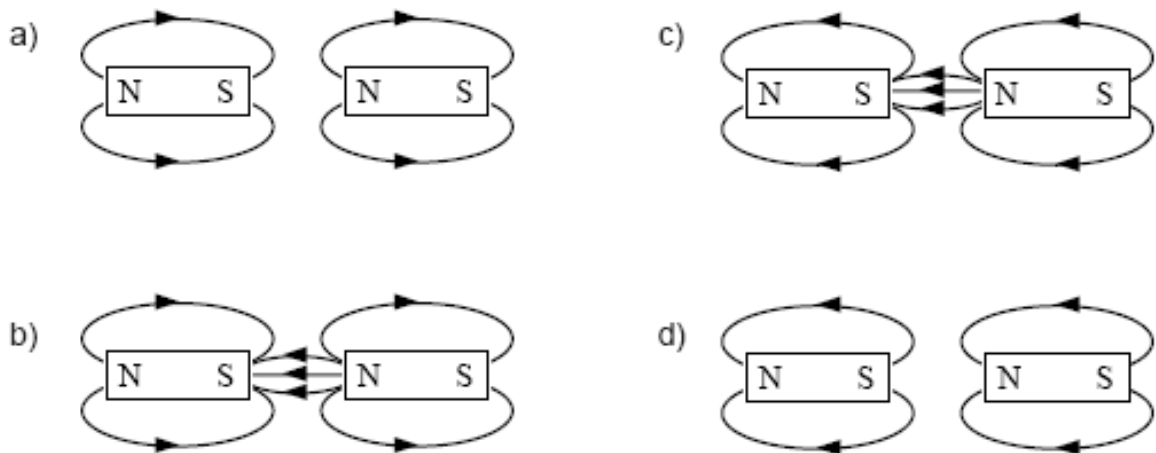

6) Does a magnetic field have a direction? \_\_\_\_\_

7) *A straight magnet always produces an external magnetic field. In which of the following diagrams is this magnetic field correctly represented?*

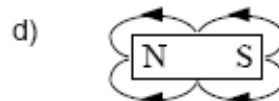
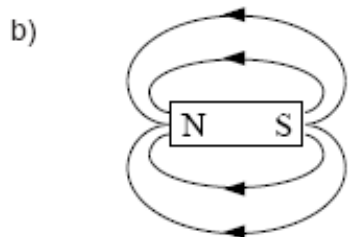
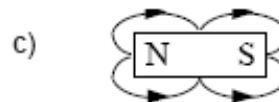
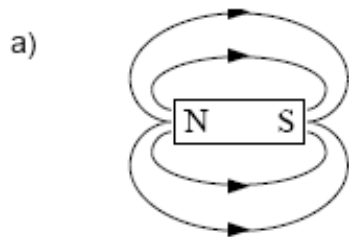

8) *Indicate the North (N) and South (S) poles in the following magnet.*

